

7/4[®]

MGR

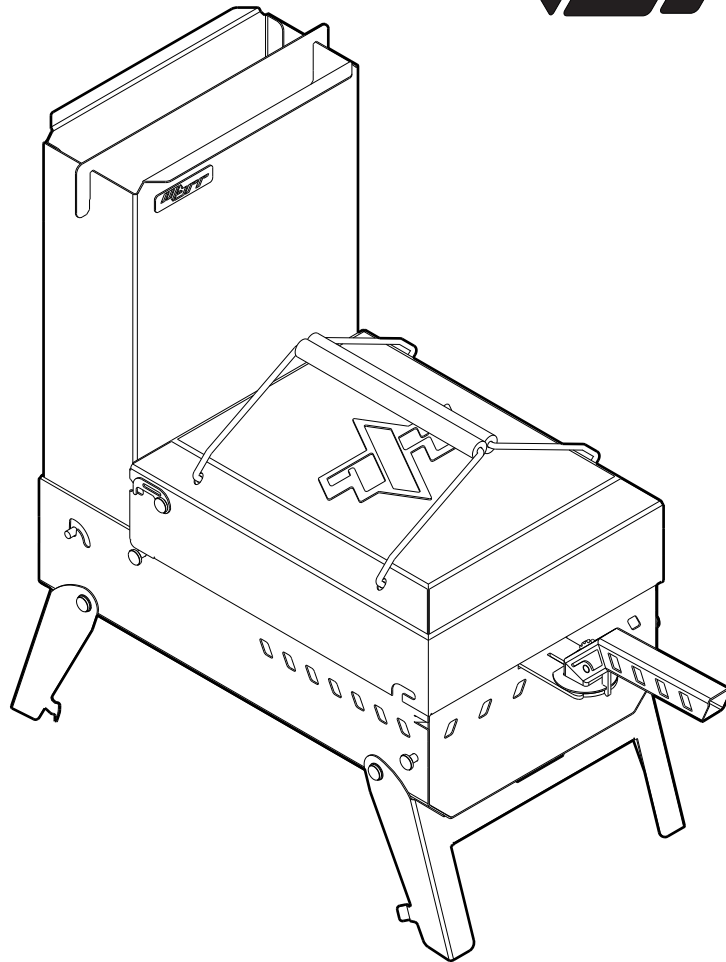

OWNER'S MANUAL

TABLE OF CONTENTS

SAFETY INSTRUCTIONS.....	1-2
MBRR PARTS LIST.....	3
OPERATING INSTRUCTIONS....	4-11
CARE AND MAINTENANCE.....	11
WARRANTY/REPLACEMENT PARTS.....	12
COMPANY INFO.....	13

SAFETY INSTRUCTIONS

**FAILURE TO FOLLOW THE BELOW SAFETY INSTRUCTIONS CONTAINED IN THIS OWNER'S MANUAL
MAY RESULT IN SERIOUS BODILY INJURY,
DEATH, OR MAY RESULT IN A FIRE OR AN EXPLOSION CAUSING DAMAGE TO PROPERTY.
YOU MUST READ THIS OWNER'S MANUAL CAREFULLY BEFORE OPERATING THE MBRR.**



WARNING



- DO NOT use the MBRR grill without a safe clearance above. This includes any structures or tree branches
- For OUTDOOR use only; Never use in a garage, roofed or enclosed porch, or veranda. Treat as an open campfire, and make sure you are not within the vicinity of any building, structure, or wall.
- Keep all combustible items at least 10 feet away from the MBRR at all times.
- DO NOT use in an explosive atmosphere. Keep grill area clear and free from gasoline, and other flammable vapors and liquids; do not store gasoline or other flammable liquids in close proximity to the MBRR.
- The MBRR is not to be used on boats or in recreational vehicles.
- When using the MBRR, fire extinguishing materials should be readily accessible. In the event of an oil/grease fire, DO NOT attempt to extinguish with water. Use type BC dry chemical fire extinguisher or smother with dirt, sand or baking soda.
- DO NOT use gasoline, kerosene, or alcohol for lighting.
- NEVER use pallet wood, pieces of furniture, or construction materials as the fuel source; Use only food safe fuel.
- NEVER use charcoal that has been pre-treated with lighter fluid. Only use wood, high grade plain charcoal, or a combination of the two.
- DO NOT leave the MBRR unattended while lit at any time. Keep children and pets away.
- NEVER add lighting fluid to hot or warm coals, as a dangerous flashback may occur.
- DO NOT remove the ashes until they are completely and fully extinguished and completely cooled.
- Extinguished coals and ashes should be placed a safe distance from all structures and combustible materials.
- DO NOT remove the ashes until they are completely and fully extinguished and completely cooled.
- The MBRR is NOT intended for, and should never be used as a space heater or furnace.
- If the above instructions are not followed exactly, Death, serious injury, or property damage may occur.



CAUTION



- DO NOT operate the MBRR without reading the “OPERATING INSTRUCTIONS” in this manual.
- For residential use only. The MBRR is not for commercial use.
- Inspect MBRR before each use.
- Position MBRR so that wind cannot carry sparks or ashes to combustible surfaces, DO NOT use in high wind.
- MBRR must be set up on a level, flat surface.
- When using the TOP GRATE to boil liquids, do not use large diameter or top heavy containers that could result in hot liquids spilling.
- DO NOT block holes in side or back of the MBRR.
- Keep all electrical cords away from the MBRR while in use.
- The use of alcohol, prescription or non-prescription drugs may impair the user’s ability to properly operate the MBRR.
- Always wear protective gloves when adding fuel (charcoal or wood).
- NEVER touch touch grate or griddle to see if they are hot.
- Do not touch the MBRR until it has completely cooled down unless you are wearing protective gear(barbeque gloves, mittens, etc.)
- NEVER lean over the grill while lighting.
- Always use a meat thermometer to ensure food is cooked to a safe temperature.
- DO NOT alter the MBRR in any way. An alteration will void your warranty.
- Improper assembly may be dangerous. Please follow the instructions in this Owner’s Manual carefully.
- Do not put an MBRR back in the bag or anything flammable on or in the MBRR while the grill is in operation or is still hot.
- While in operation, the MBRR is very hot - take special care when children or elderly people are present.
- Use only 7/4 factory-authorized parts. The use of any part that is not factory-authorized can be dangerous and will void your warranty.



CALIFORNIA PROPOSITION 65



- WARNING: Combustion byproducts near this grill include carbon monoxide, a chemical known to the State of California to cause birth defects or other reproductive harm.
- WARNING: This product can expose you to chemicals including Chromium (hexavalent compounds), which is known to the State of California to cause cancer and birth defects or other reproductive harm.
- WARNING: Using this product can expose you to chemicals including soot, which is known to the State of California to cause cancer, and carbon monoxide, which is known to the State of California to cause birth defects or other reproductive harm.

For more information go to: www.P65Warnings.ca.gov

MBRR PARTS LIST

CHIMNEY

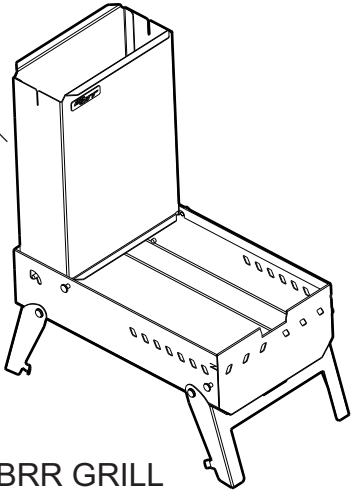

MBRR GRILL

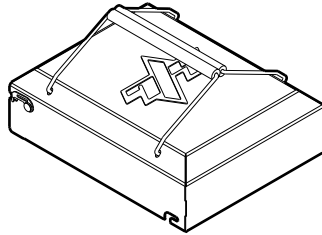

LID ASSEMBLY

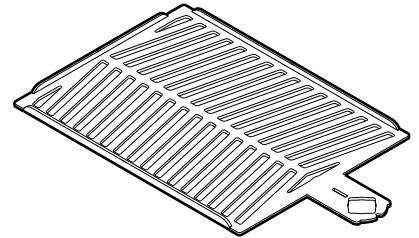

GRATE

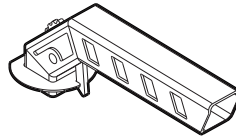

HANDLE

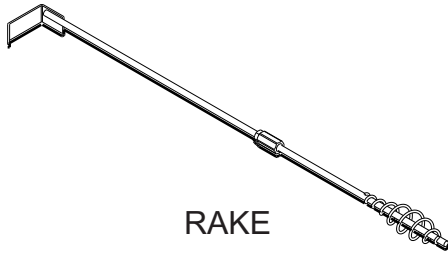

RAKE

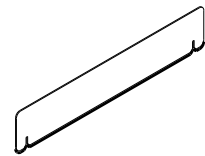

TOP GRATE

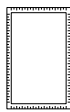

WIPES

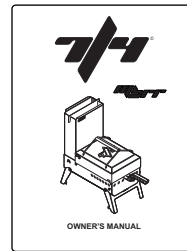

OWNER'S MANUAL

ITEMS SOLD SEPARATELY

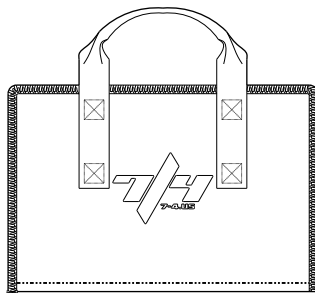

BAG

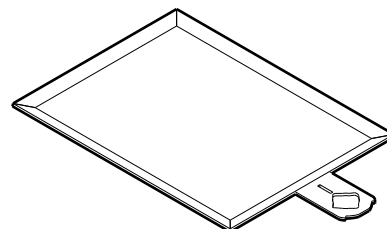

GRIDDLE

OPERATING INSTRUCTIONS



!! IMPORTANT !!



WIPE DOWN OF GRILL MUST OCCUR BEFORE FIRST USE

INITIAL USE

Make sure all labels, packaging and protective films have been removed from the grill.

After following the instructions below for setting up the grill and loading fuel, a thorough **WIPE DOWN** of the grill must be performed before the initial **BURN IN**. This is to ensure optimum finish of the stainless steel in your MBRR, without fingerprints. Use the wipes included with your MBRR.

The initial **BURN IN** should be done for approximately 15 minutes with the **LID ASSEMBLY** closed. This will 'heat clean' the internal parts, removing manufacturing oils and dissipating odors. Make sure the entire unit is completely cool before storing your MBRR.

SETUP

Choose a safe surface and location for setting the MBRR, being sure to follow the safety instructions contained in this Owner's Manual.

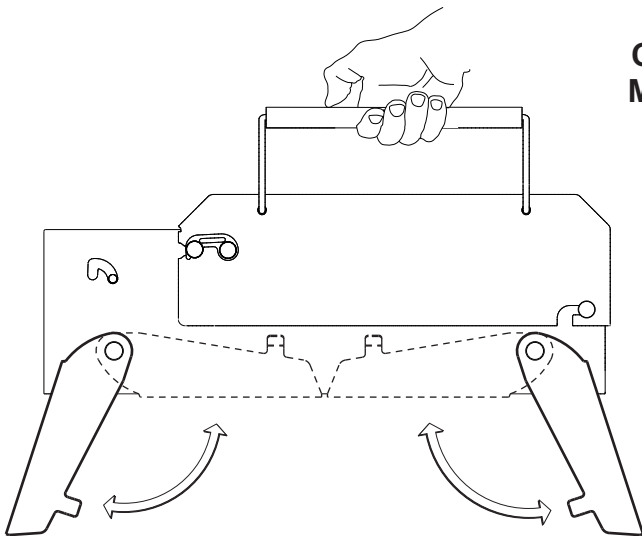

Remove MBRR from the bag using the **LID ASSEMBLY** handles, and fold the legs down.

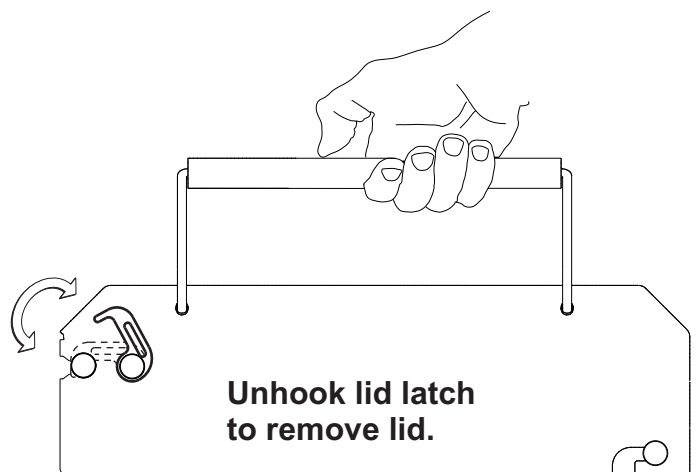

Unhook lid latch to remove lid.

OPERATING INSTRUCTIONS

SETUP (CONT'D)

Rotate CHIMNEY up to gain access and remove the GRIDDLE, GRATE, and RAKE

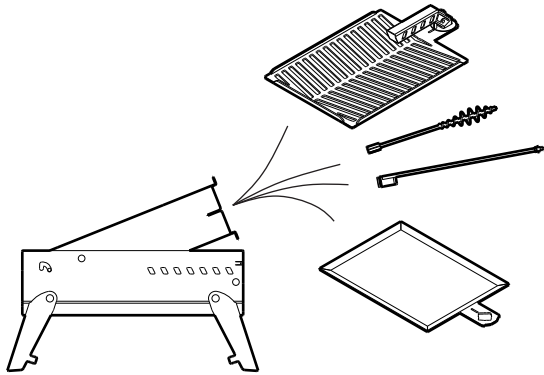

Rotate CHIMNEY to 90 degrees and pop into "LOCKED" position

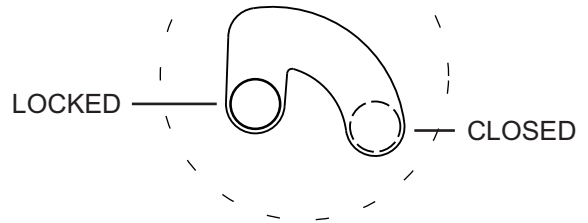
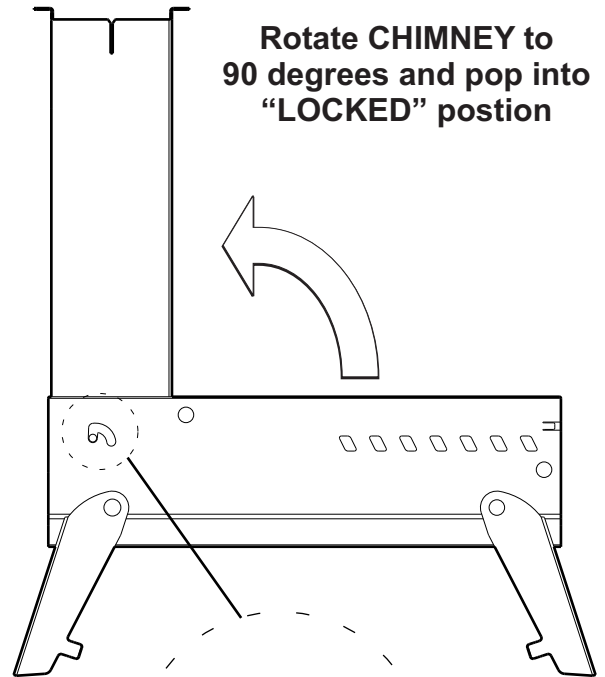

Use THUMBWHEEL to unlock HANDLE from GRATE. Rotate HANDLE 180 degrees to lock into position for use

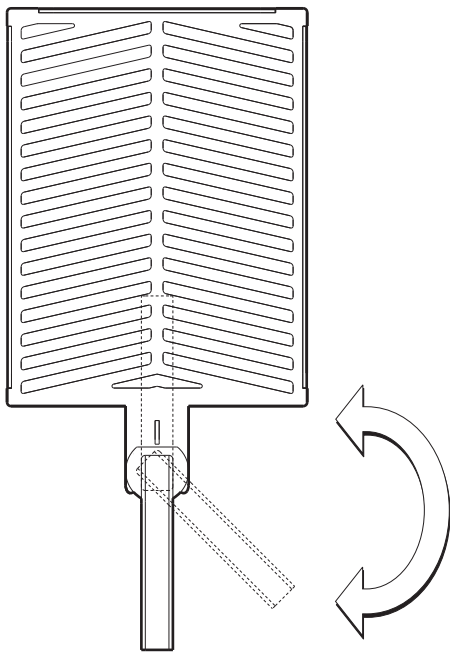

THUMBWHEEL

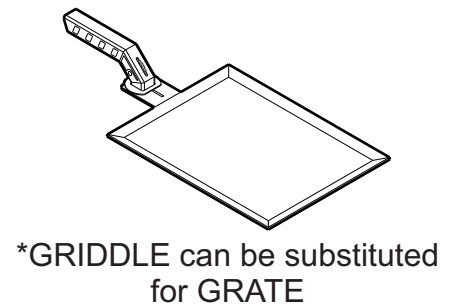
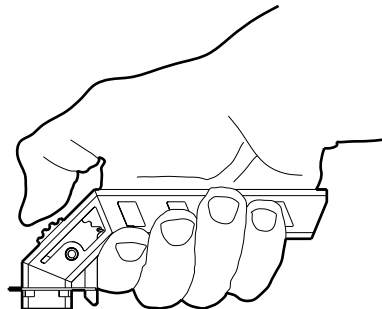

*GRIDDLE can be substituted for GRATE

OPERATING INSTRUCTIONS

SETUP (CONT'D)

KEEP THE MBRR A SAFE DISTANCE FROM:
TRASH, WOOD, OR CLOTH
ANY STRUCTURES (EX. HOUSE, FENCE, PAVILLIONS, ETC)
FLAMMABLE LIQUIDS OR VAPORS
OVERHEAD STRUCTURES OR TREES.

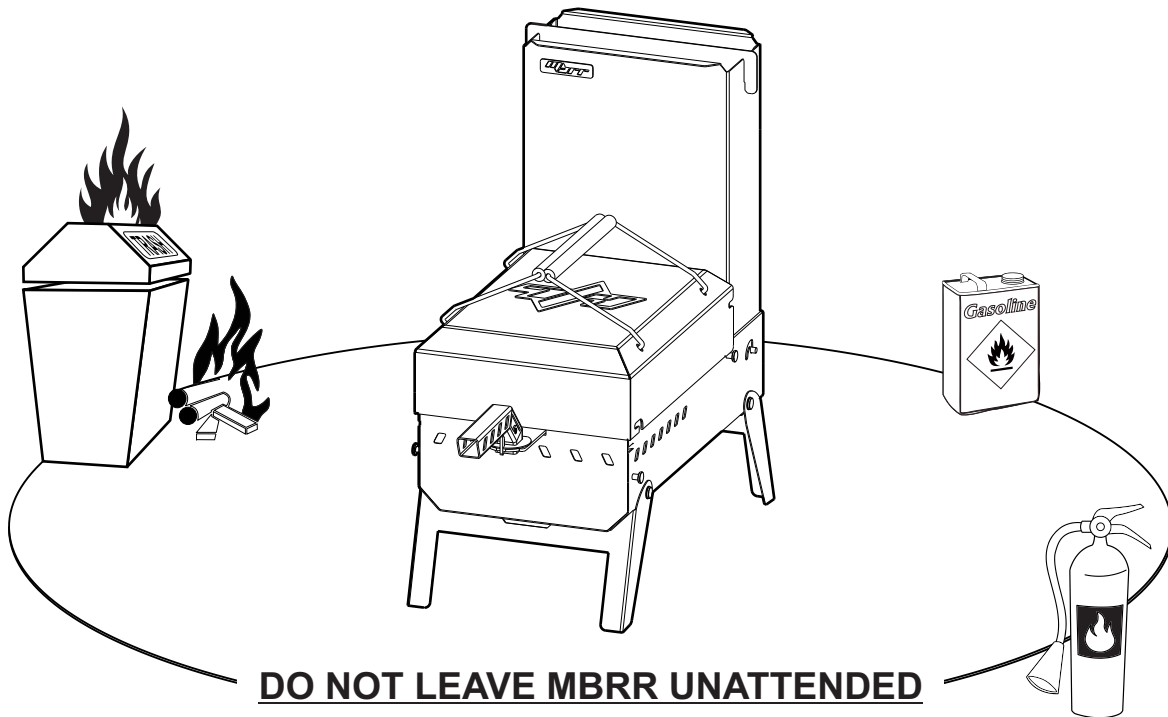

When choosing a cooking location, be sure there is ample clearance above the MBRR

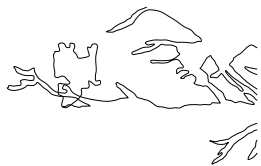

YES

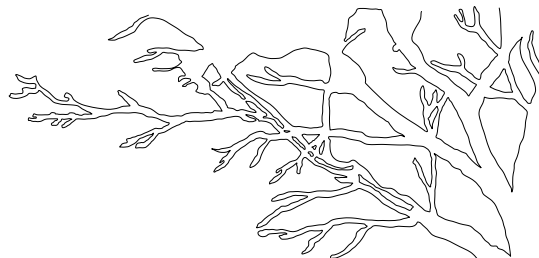
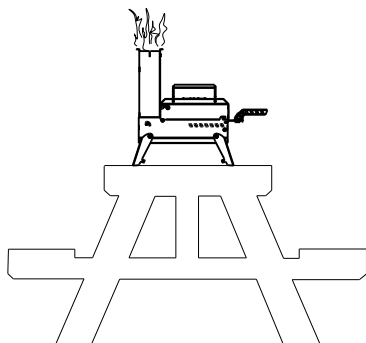

NO

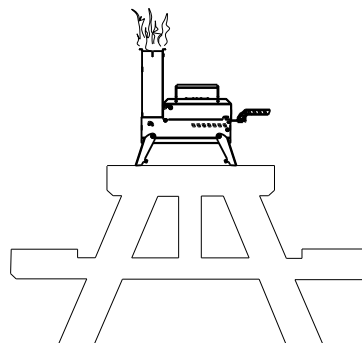

OPERATING INSTRUCTIONS

SETUP - LOADING FOOD SAFE FUEL

Your MBRR grill is intended to be used with wood or charcoal (or a combination of the two).

WOOD

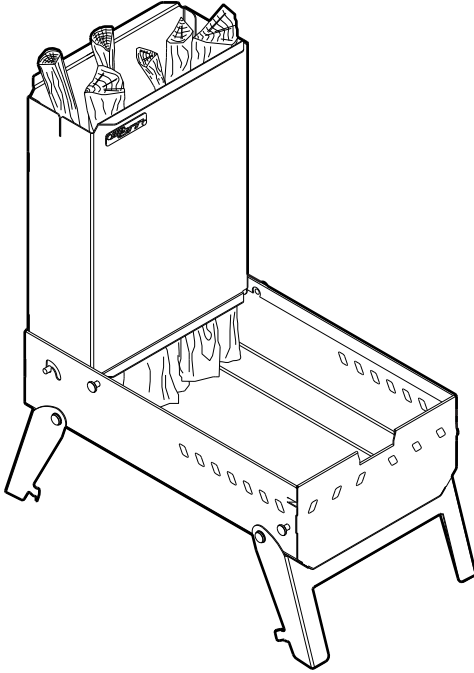

- Use dry sticks or split wood approximately 2” wide and 8”-14” long.
- Load sticks vertically in chimney, fill approximately half full.
- For optimum lighting, crumple paper or other kindling around base of sticks.
- Make sure your fuel is food safe; Some wood naturally contains toxins and should not be used for cooking.

CHARCOAL

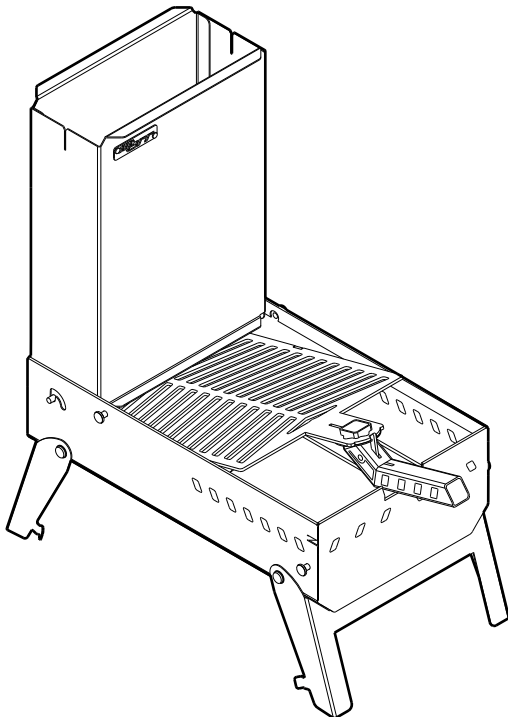

- With HANDLE and GRATE assembled, flip GRATE upside down and rest handle in notch of grill (see image to the left).
- This keeps the charcoal in the CHIMNEY while being lit.
- Dump charcoal into top of CHIMNEY
- A chimney half full of charcoal should be sufficient for an average meal.

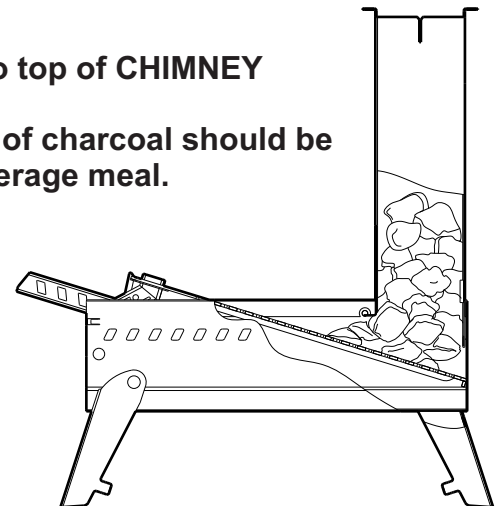

OPERATING INSTRUCTIONS

WIPING DOWN BEFORE FIRST USE

Your MBRR is made of high quality stainless steel, and will change color when heated. To ensure a nice even patina with no fingerprints, wipe down the entire MBRR before its initial firing using the WIPES included (or stainless steel appliance wipes). Use the wet wipe first, followed by the dry wipe to clear the excess residue.

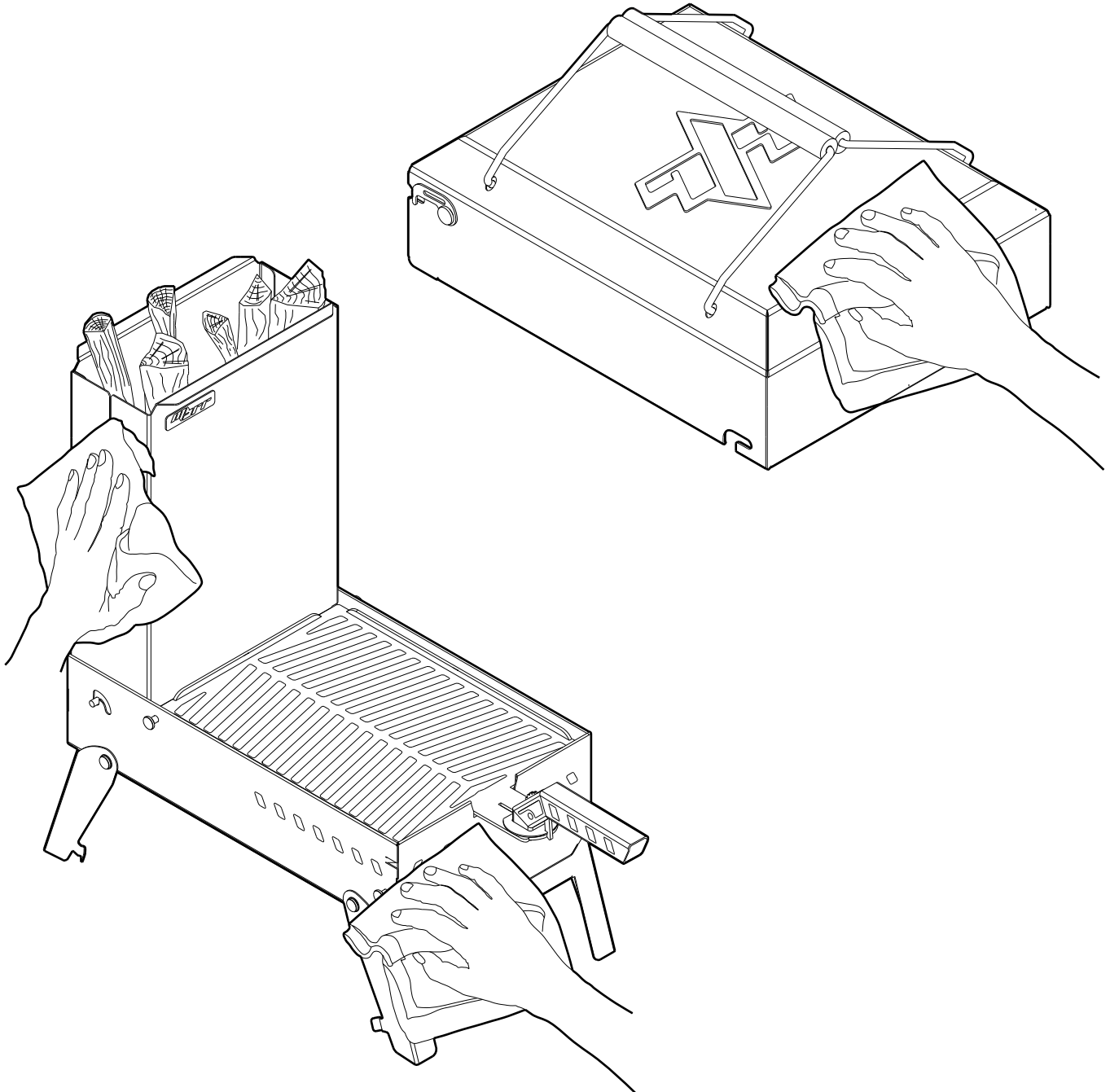

OPERATING INSTRUCTIONS

COOKING

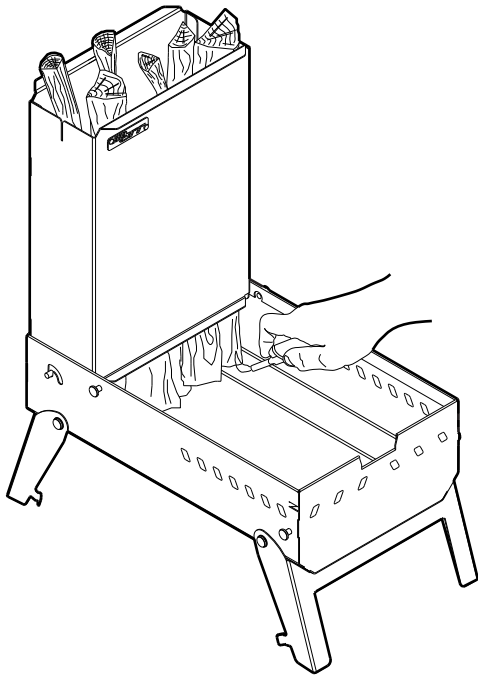

Light the wood or charcoal at the base of the CHIMNEY. Crumpled paper or small kindling will help the fire start quickly.

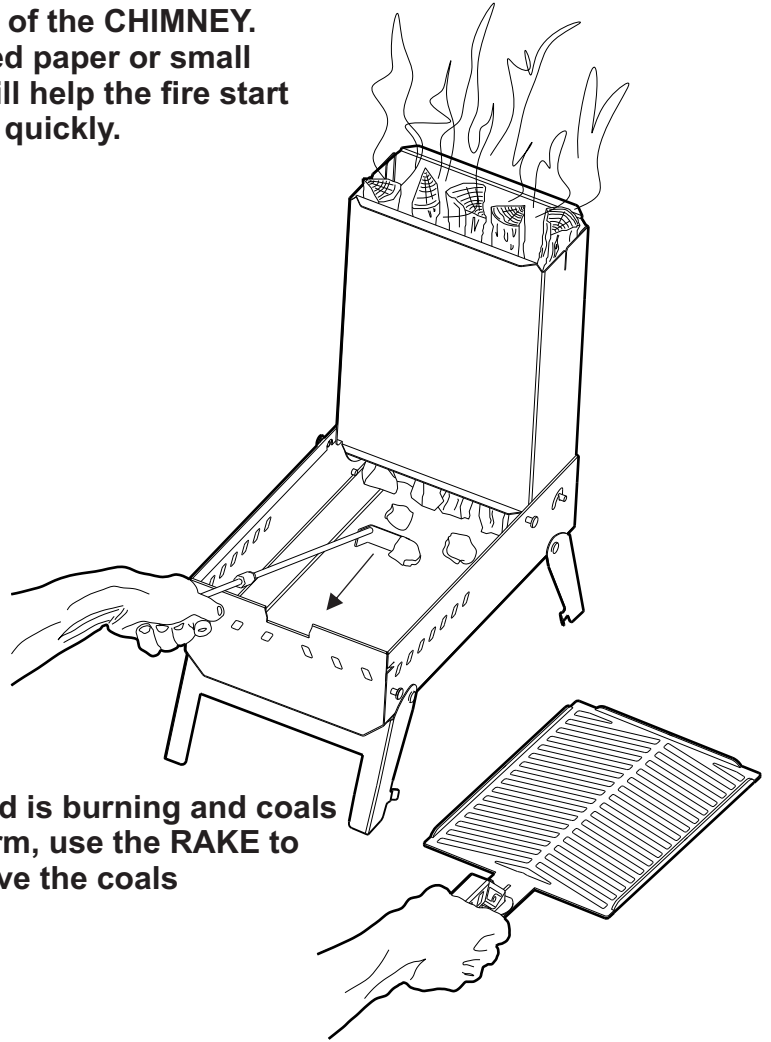

Once the wood is burning and coals begin to form, use the RAKE to move the coals

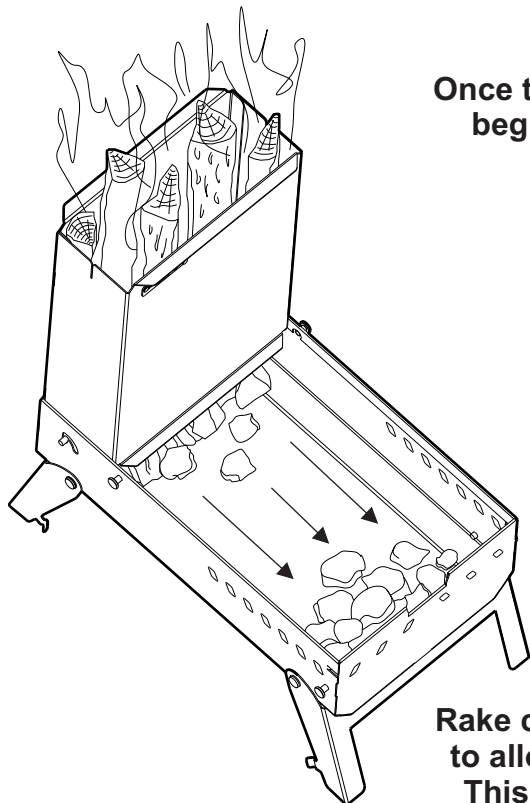

Rake coals to the front of the MBRR to allow the air to pass over them. This will allow for even cooking.

OPERATING INSTRUCTIONS

COOKING (CONT'D)

GRATE VS. GRIDDLE

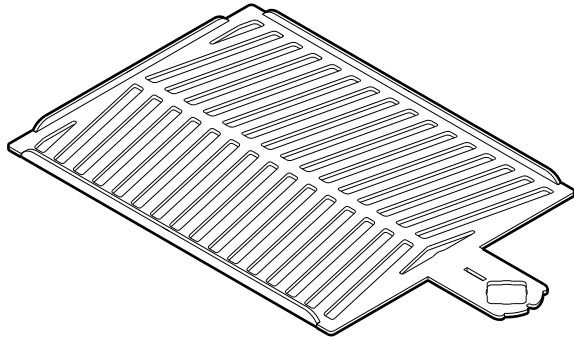

Use the **GRATE** for open flame, direct heat and smoke. Get perfect grill marks on meat, veggie's, fish etc.

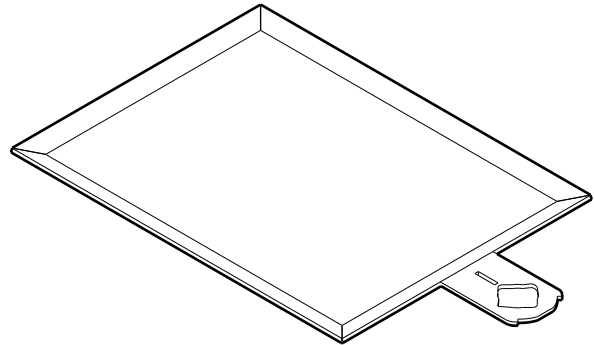

Use the flat cooking surface of the **GRIDDLE** for flaky fish, eggs, etc. Cook anything that needs a flat even surface.

* Purchased Separately

USING THE TOP GRATE

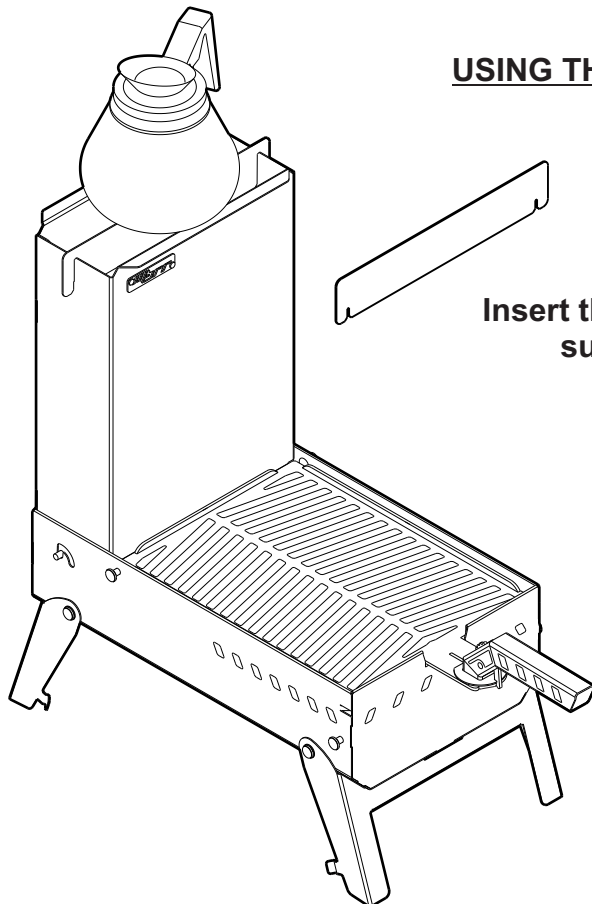

Insert the **TOP GRATE** into the **CHIMNEY** to support a small pot or frying pan



CAUTION



Heating water or other liquids on the chimney can be dangerous. The pot may be easily spilled or may tip the entire grill over. Make sure the grill is on a stable, non-flammable, and flat level surface.

OPERATING INSTRUCTIONS

POST COOKING CLEANUP

WHEN FINISHED COOKING WITH THE MBRR:

- Allow wood / charcoal to completely extinguish itself, and for the MBRR to cool completely.
- Dispose of the ashes in a proper location
- The TOP GRATE, RAKE, GRATE, GRIDDLE, and HANDLE are all stored in the CHIMNEY. HANDLE can be stored in the CHIMNEY loose, or attached to the GRIDDLE/GRATE once it is rotated 180 degrees from the 'IN USE' position
- Fold CHIMNEY down into the base
- Fold legs up
- Use LID LATCH to lock LID ASSEMBLY in place before stowing

CARE AND MAINTENANCE

Your MBRR can be cleaned with warm, soapy water. Use a scrub pad for difficult stains on the GRIDDLE/GRATE.

WARRANTY

LIMITED WARRANTY ON MBRR

THIS LIMITED WARRANTY GIVES YOU SPECIFIC LEGAL RIGHTS AND YOU MAY ALSO HAVE OTHER RIGHTS, WHICH VARY FROM STATE TO STATE.

WE WARRANT THAT DURING THE WARRANTY PERIOD, THE PRODUCT WILL BE FREE FROM DEFECTS IN MATERIALS AND WORKMANSHIP BUT DOES NOT EXTEND TO DISCOLORATION OR WARPING OF THE MBRR. WE LIMIT THE DURATION AND REMEDIES OF ALL IMPLIED WARRANTIES, INCLUDING WITHOUT LIMITATION THE WARRANTIES OF MERCHANTABILITY AND FITNESS FOR A PARTICULAR PURPOSE TO THE DURATION OF THIS EXPRESS LIMITED WARRANTY. OUR RESPONSIBILITY FOR DEFECTIVE GOODS IS LIMITED TO REPAIR, REPLACEMENT OR REFUND AS DESCRIBED BELOW IN THIS WARRANTY STATEMENT.

WHO MAY USE THIS WARRANTY?

SEVEN FOUR LLC, A PENNSYLVANIA LIMITED LIABILITY COMPANY ("WE") EXTEND THIS LIMITED WARRANTY ONLY TO THE CONSUMER WHO ORIGINALLY PURCHASED THE PRODUCT ("YOU"). IT DOES NOT EXTEND TO ANY SUBSEQUENT OWNER OR OTHER TRANSFEREE OF THE PRODUCT.

WHAT DOES THIS WARRANTY COVER?

THIS LIMITED WARRANTY COVERS DEFECTS IN MATERIALS AND WORKMANSHIP OF THE MBRR (THE "PRODUCT") FOR THE WARRANTY PERIOD AS DEFINED BELOW.

WHAT DOES THIS WARRANTY NOT COVER?

THIS LIMITED WARRANTY DOES NOT COVER ANY DAMAGE DUE TO: (A) TRANSPORTATION; (B) STORAGE; (C) IMPROPER USE; (D) FAILURE TO FOLLOW THE PRODUCT INSTRUCTIONS OR TO PERFORM ANY PREVENTIVE MAINTENANCE; (E) MODIFICATIONS; (F) UNAUTHORIZED REPAIR; (G) NORMAL WEAR AND TEAR; OR (H) EXTERNAL CAUSES SUCH AS ACCIDENTS, ABUSE, OR OTHER ACTIONS OR EVENTS BEYOND OUR REASONABLE CONTROL.

WHAT IS THE PERIOD OF COVERAGE?

THIS LIMITED WARRANTY STARTS ON THE DATE OF YOUR PURCHASE AND LASTS FOR TWO (2) YEARS (THE "WARRANTY PERIOD"). THE WARRANTY PERIOD IS NOT EXTENDED IF WE REPAIR OR REPLACE THE PRODUCT. WE MAY CHANGE THE AVAILABILITY OF THIS LIMITED WARRANTY AT OUR DISCRETION, BUT ANY CHANGES WILL NOT BE RETROACTIVE.

WHAT ARE YOUR REMEDIES UNDER THIS WARRANTY?

WITH RESPECT TO ANY DEFECTIVE PRODUCT DURING THE WARRANTY PERIOD, WE WILL, IN OUR SOLE DISCRETION, EITHER: (A) REPAIR OR REPLACE SUCH PRODUCT (OR THE DEFECTIVE PART) FREE OF CHARGE, OR (B) REFUND THE PURCHASE PRICE OF SUCH PRODUCT. WE WILL ALSO PAY FOR SHIPPING AND HANDLING FEES TO RETURN THE REPAIRED OR REPLACEMENT PRODUCT TO YOU IF WE ELECT TO REPAIR OR REPLACE THE DEFECTIVE PRODUCT.

HOW DO YOU OBTAIN WARRANTY SERVICE?

TO OBTAIN WARRANTY SERVICE, YOU MUST EMAIL OUR CUSTOMER SERVICE DEPARTMENT AT: customerservice@7-4.us DURING THE WARRANTY PERIOD TO OBTAIN WARRANTY SERVICE.

LIMITATION OF LIABILITY

THE REMEDIES DESCRIBED ABOVE ARE YOUR SOLE AND EXCLUSIVE REMEDIES AND OUR ENTIRE LIABILITY FOR ANY BREACH OF THIS LIMITED WARRANTY. OUR LIABILITY SHALL UNDER NO CIRCUMSTANCES EXCEED THE ACTUAL AMOUNT PAID BY YOU FOR THE DEFECTIVE PRODUCT, NOR SHALL WE UNDER ANY CIRCUMSTANCES BE LIABLE FOR ANY CONSEQUENTIAL, INCIDENTAL, SPECIAL OR PUNITIVE DAMAGES OR LOSSES, WHETHER DIRECT OR INDIRECT.

CONTACT

SEVEN FOUR LLC
735 Global Circle
Hunker, PA 15639
United States

(724)204-1515
www.7-4.us

